

KARNATAKA SECONDARY EDUCATION EXAMINATION BOARD
MODEL QUESTION PAPER 2018-19 (Set 2)

Subject: Science-83E

Time: 3 hours

Marks: 80

I. Four alternatives are provided for each question. Choose the most appropriate alternative and write it along with its alphabet.

10 x 1 = 10

1.

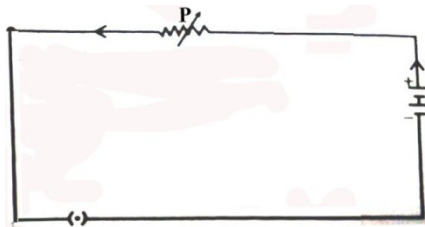

In the figure the device labelled as P is

- A) Ammeter B) Bulb C) Rheostat D) Voltmeter
2. In the following reactions, the chemical reaction that takes place in sunlight is
- A) $CaCO_3 \rightarrow CaO + CO_2$ B) $CuSO_4 \cdot 5H_2O \rightarrow CuSO_4 + 5H_2O$
C) $2AgBr \rightarrow 2Ag + Br_2$ D) $2HgO \rightarrow 2Hg + O_2$
3. Method of managing used envelopes: Reuse :: Method of managing fuels:
- A) Recycling B) Use for repurpose
C) Reduce the use D) Refuse the use
4. The magnetic field around a current carrying circular loop can be increased by
- A) increasing the radius of the coil.
B) converting the coil into straight wire.
C) decreasing the radius of the coil.
D) reducing the amount of electric current through the coil.
5. The part of the human eye that controls the amount of light entering into the eye is
- A) iris B) pupil C) rod and cone D) retina

6. In a fertile garden certain types of flower plants were not growing. After testing the soil of the garden it was found that its pH value is 5. The chemical that may be used to treat the soil is
- A) Sodium chloride B) Calcium hydroxide
C) Urea D) Copper sulphate
7. A multicellular organism that shows the development of tiny individuals on one side of mother's body is
- A) Hydra B) Yeast C) Planaria D) Spirogyra
8. Flow of energy is unidirectional in an ecosystem because in each trophic level
- A) Number of consumers is constant
B) Number of consumers reduces
C) Loss of energy is more than the amount of available energy
D) Available energy is completely consumed by consumers
9. One of the effects of refraction among the following is
- A) Formation of image in a mirror
B) Appearance of flowers in different colours
C) The sky appears blue in colour
D) The pencil immersed in water appears to be bent
10. An event that may happen in heterotrophic nutrition is
- A) Conversion of carbon dioxide into carbohydrate
B) Unused carbohydrates are stored in the form of starch
C) Excess of glucose converts into glycogen.
D) Water molecules decompose into hydrogen and oxygen molecules

11. The properties of metals are given in column 'A' and examples are given in column 'B' Match them and write the answer along with its alphabet.

4 x 1 = 4

Column 'A'	Column 'B'
i Reacts with cold water	a) Iron
ii Forms amphoteric oxide	b) Magnesium
iii Exists in liquid state at room temperature	c) Aluminum
iv Best conductor of heat	d) Sodium
	e) Silver
	f) Lead
	g) Mercury

II. Answer the following questions:

7 x 1 = 7

12. Name the type of the mirror that always produces virtual image. Mention one use of this mirror.
13. Identify the reactants which are oxidized and which are reduced in the following chemical reaction.
 $\text{CuO} + \text{H}_2 \rightarrow \text{Cu} + \text{H}_2\text{O}$
14. Genes related to one character has two contrast traits. But only one among them is considered as dominant. How?
15. Name the gaseous products obtained by the electrolysis of aqueous sodium chloride solution.
16. Fuse wire should have higher resistance than the other wires in the circuit but it should not have high melting point. Why?
17. What is the reason for the formation of food webs in an ecosystem?
18. Small intestine is called the site of complete digestion. Why?

III. Answer the following questions:

16 x 2 = 32

19. Explain briefly the breathing cycle in the human body.

OR

Explain the strategy of transportation of water to the highest points of the plant body by the xylem tissue.

20. Draw the diagram to show the structure of nephron and label Bowman's capsule.

21. Draw the diagram showing the magnetic field lines around a current carrying conductor. Label the following.

- i) The direction of magnetic field lines
- ii) The direction of electric current

22. What is electric power? Write any two formulae used to calculate electric power.

OR

What is electric current? Which is the device used to measure electric current in the circuit? How should that device be connected in the circuit?

23. Draw the diagram of the apparatus used to demonstrate that acidic solutions conduct electricity. Label the following parts.

- i) The solution taken
- ii) Source of electric current

24. With the help of the following pattern briefly explain the reason for a) DNA Stability

b) Variation phenomenon found in the successive generation of species.

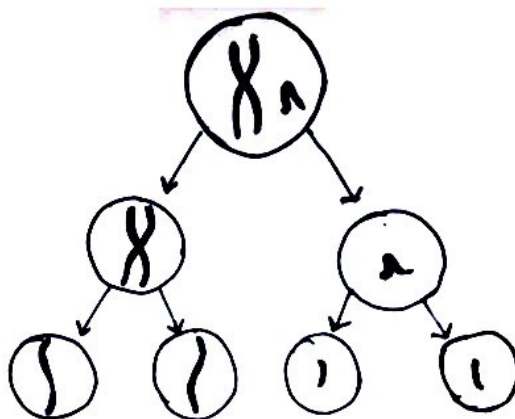

25. How are dilute acid and weak acid different from one another? What are the precautions to be taken while diluting an acid?

26. What is electromagnetic induction? Name the device that works on this principle. Mention the frequency of the electric current produced in India.

OR

What is magnetic field? Write the two properties of magnetic field lines.

27. Related to water harvesting system mention

A) two advantages of rejuvenating indigenous methods

B) two disadvantages by the construction of huge dams

OR

What are the advantages of harvesting water by setting of the khadinsystem.

28. Draw the diagram of the apparatus used to show that water is a compound of hydrogen and oxygen. Label the following parts.

i) The part where oxygen is collected

ii) The part where hydrogen is collected

29. In the figure calculate the total electric current flowing in the circuit.

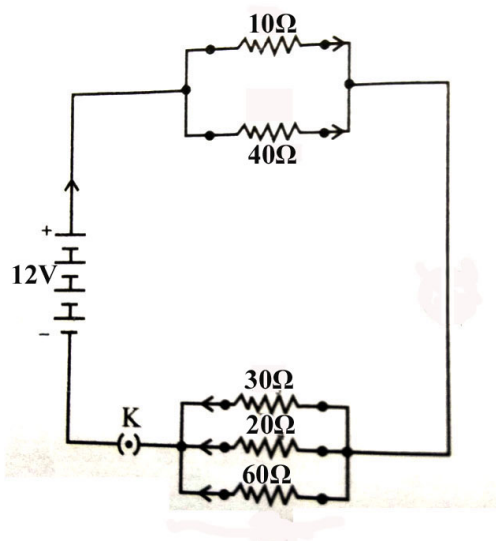

30. In multicellular organisms compared to electrical communication chemical communication is more steady and persistent. Analyse this statement.

31. Observe the following reactions

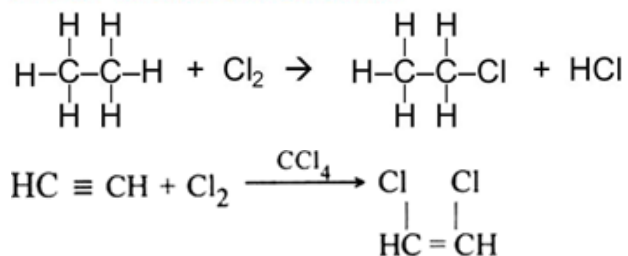

State whether these reactions are addition reactions or substitution reactions. Justify your answer.

OR

You are given ethanol, concentrated sulphuric acid and a small piece of sodium metal. Using these chemicals, how do you prepare

i) Hydrogen gas?

ii) Ethene gas?

32. Draw the ray diagram showing the image formation by a convex lens when the object is placed between $2F_1$ and F_1 of the lens. (F_1 : Principal focus of the lens)

33. Sample of an ore is heated in a test tube. In the beginning a gas is evolved which turns wet blue litmus red. On further heating a gas is evolved which makes a glowing splinter burn brilliantly. A shining greyish metal appears in the test tube. Study the data and answer the following questions.

i) What are the two gases produced?

ii) What is the possible name of the ore?

iii) Which is the metal produced in the test tube?

34. A person connects a bulb having resistance and an electric heater having resistance in series. But they do not work properly. When he connects the same appliances in parallel in the circuit, they function normally. Explain the reason for this.

IV. Answer the following questions:

5 x 3 = 15

35. The focal length of a converging mirror is 4cm. If the object of height 2cm is placed from the mirror, then find the image distance, nature and size of the image.

OR

The velocity of light in water and kerosene are $2.25 \times 10^8 \text{ms}^{-1}$ and $2.08 \times 10^8 \text{ms}^{-1}$ respectively. Which material has highest refractive index? Prove your answer by calculation.

36. (i) What is the advantage of using atomic number instead of atomic mass while constructing modern periodic table?

(ii) Sodium and chlorine are placed in the third period of the modern periodic table with group and respectively. State their valency. Which of them can form anion? Which of them can form cation? Give reason for your answer.

37. Read the following information and answer the given questions.

- Thousands of years ago only one species of squirrels was there and were evolved from common ancestor.
- At present there are two species of squirrels, though they have similarities among them, cannot perform reproduction between them.
 - a) Analyze the factor responsible for this change.
 - b) How can this kind of changes be considered as beneficial for species?

OR

Justify the following statements with one illustration each

- a) Though organs of different organisms have more similarities in the shapes of organs they need not be evolved from common ancestor.
- b) Though the variations are more between the organisms, they might have been evolved from common ancestor.

38. Draw the schematic diagram of gobar gas plant. Label the following parts.

- (i) Slurry
- (ii) Gas outlet

39. Draw the diagram showing longitudinal section of the human brain. Label the following parts

- (i) Thinking centre
- (ii) The part that regulates body balance

V. Answer the following questions:

3 x 4 = 12

40. a) Explain the phenomenon of formation of rainbow in the sky.
b) Stars appear to twinkle but planets do not appear to twinkle why?

OR

- a) Explain Tyndall effect with an example.
b) Explain Presbyopia. How can this be corrected?

41 a) Write the molecular formula of the following and show that they form homologous series.

- i) Methanol ii) Ethanol iii) Propanol

b) Write the equation of the chemical reaction taking place when ethanol is heated with alkaline potassium permanganate and name the product.

42 a) Write the two differences between self pollination and cross pollination.

b) "The structure and function of placenta plays important role at the time of gestation period". Explain.